

MODEL PSM® 400 HARDWIRED PERSONAL PERFORMANCE PACK

PSM[®] 400 HARDWIRED PERSONAL PERFORMANCE PACK

TABLE OF CONTENTS

INTRODUCTION	2
BASIC SYSTEM SET-UP	2
P4M PERSONAL MONITOR MIXER	3
Features	3
Using the P4M Personal Monitor Mixer	4
P4HW HARDWIRED PERSONAL MONITOR	5
Controls	5
Battery Installation	5
Connecting to Mixer	5
Reading the LCD Screen	6
Using the Bodypack Features	6
Locking the Display	6
Mono, Stereo and MixMode [®] Control	7
P4M PERSONAL MONITOR MIXER SPECIFICATIONS	8
P4HW PERSONAL MONITOR SPECIFICATIONS	9
CERTIFICATIONS	9
RACK MOUNTING	10



This symbol indicates that there are important operating and maintenance instructions in the literature accompanying this unit.



WARNING!

**USING THIS SYSTEM AT EXCESSIVE VOLUMES CAN CAUSE PERMANENT HEARING DAMAGE.
USE AS LOW A VOLUME AS POSSIBLE.**

In order to use this system safely, avoid prolonged listening at excessive sound pressure levels. Please use the following guidelines established by the Occupational Safety Health Administration (OSHA) on maximum time exposure to sound pressure levels before hearing damage occurs.

- 90 dB SPL at 8 hours
- 95 dB SPL at 4 hours
- 100 dB SPL at 2 hours
- 105 dB SPL at 1 hour
- 110 dB SPL at 1/2 hour
- 115 dB SPL at 15 minutes

120 dB SPL—avoid or damage may occur

It is difficult to measure the exact Sound Pressure Levels (SPL) present at the eardrum in live applications. In addition to the volume setting on the PSM, the SPL in the ear is affected by ambient sound from floor wedges or other devices. The isolation provided by the fit of quality earphones is also an important factor in determining the SPL in the ear.

Here are some general tips to follow in the use of this product to protect your ears from damage:

- Turn up the volume control only far enough to hear properly.
- Ringing in the ears may indicate that the gain levels are too high. Try lowering the gain levels.
- Have your ears checked by an audiologist on a regular basis. If you experience wax buildup in your ears, stop using the system until an audiologist has examined your ears.
- Wipe the earphones with an antiseptic before and after use to avoid infections. Stop using the earphones if they are causing great discomfort or infection.

INTRODUCTION

Thank you for choosing the Shure PSM[®] 400 Hardwired Personal Performance Pack. Like all Shure personal monitoring systems, the PSM 400 provides the advantages of an in-ear monitor, including:

- **Improved Sound Quality**—high fidelity without the risk of feedback
- **Personal Control**—monitor mixes created and controlled by performer
- **Portability**—small form factor, easy set-up and tear down

The PSM 400 Hardwired Personal Performance Pack includes the P4M Personal Monitor Mixer, the P4HW Hardwired Personal Monitor, the E3 earphones, the PS40 power supply, and 1/4" to male XLR patching cables.

BASIC SYSTEM SET-UP

- ① Connect PS40 power source.

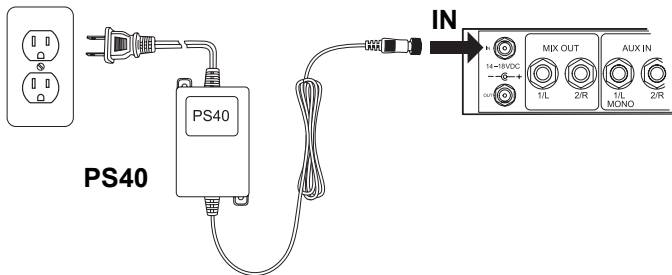

- ② Connect audio sources.

CAUTION: Use a direct box to connect keyboards, guitars, and other instruments.

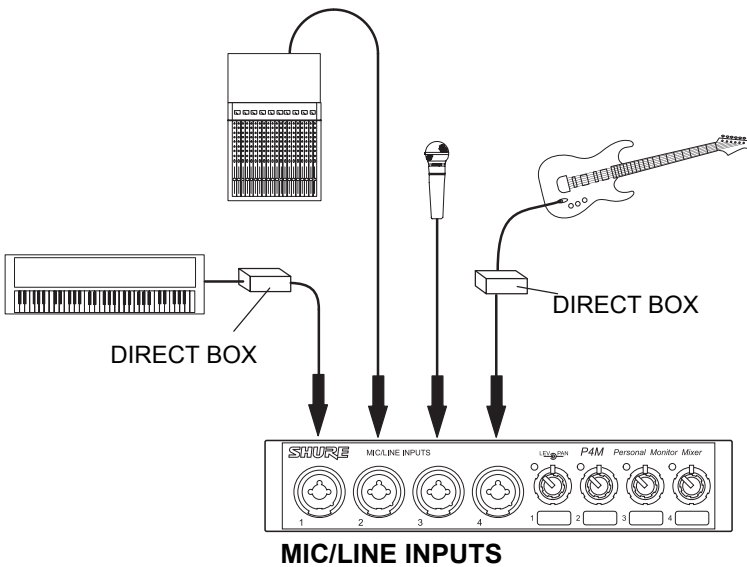

- ③ Connect bodypack to the MIX OUT jacks using the 1/4" to XLR patching cables.

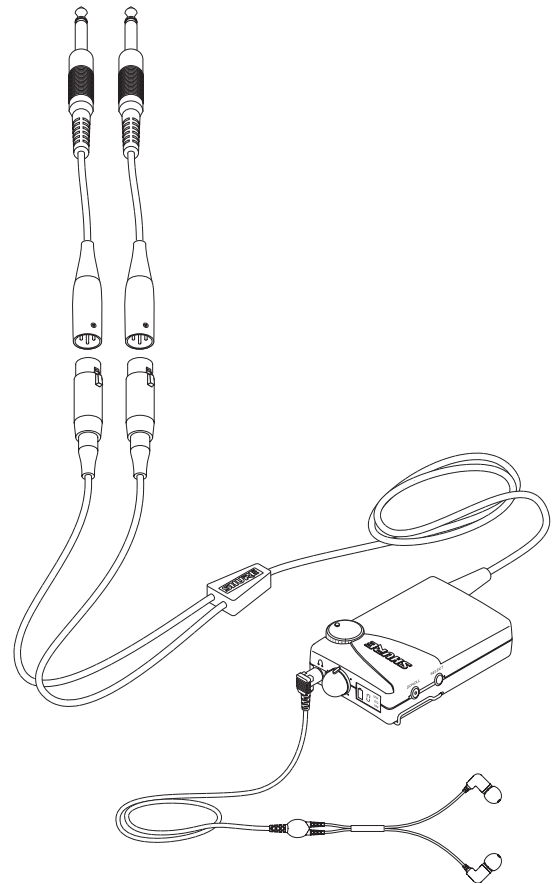
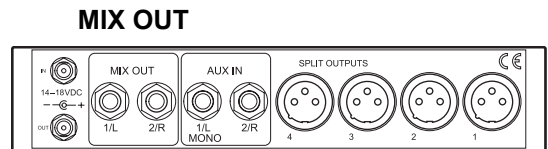

P4M PERSONAL MONITOR MIXER

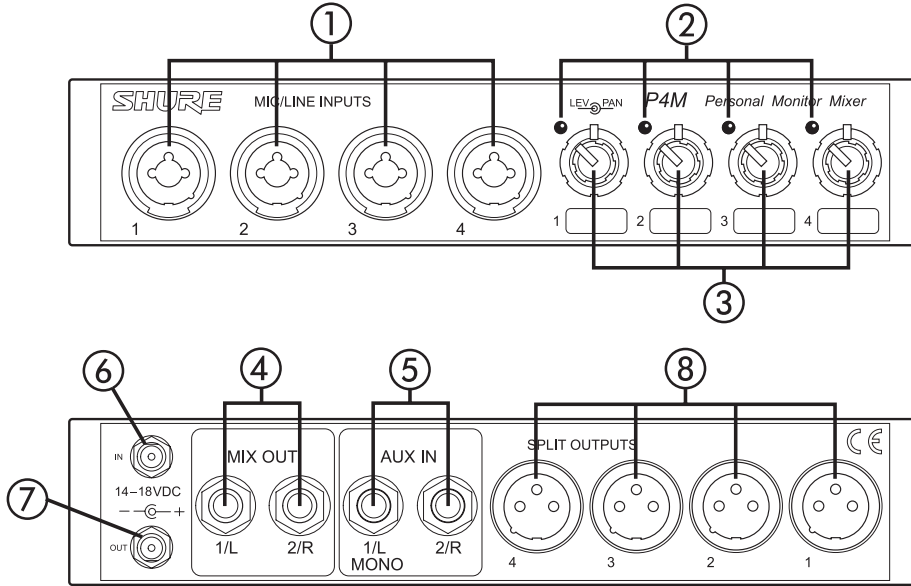

Features

- ❶ **MIC/LINE INPUT Jacks:** Accommodate both XLR and 1/4" connectors at mic or line levels. They are electronically balanced.
- ❷ **Signal/Clip LEDs:** Color indicates the signal status of the corresponding MIC/LINE input:

LED Color	Signal Status
Green	Signal present
Yellow	Nominal Level
Red	Signal clipping

- ❸ **CONCENTRIC LEVEL/PAN Knobs:** The inner knob controls the input level; the outer ring pans the input signal between the 1/L and 2/R mix outputs.

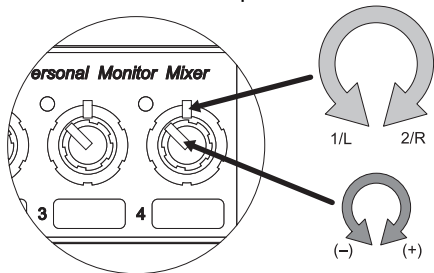

- ❹ **MIX OUT Output Jacks:** 1/4" TRS jacks provide the line level mix created with the CONCENTRIC LEVEL/PAN knobs.
- ❺ **AUX IN Inputs:** Signals from the two 1/4" TRS input jacks are combined with the mix created by the CONCENTRIC LEVEL/PAN knobs. Front panel settings do not affect these jacks.
- ❻ **DC IN Locking Connector:** Plug the PS40 AC adaptor into this connector.
- ❼ **DC OUT Locking Connector:** Powers a P4T Transmitter or another P4M Mixer. A DC jumper cable is provided with the P4M.
- ❽ **SPLIT OUTPUT Jacks:** Each male XLR output provides a duplicate of its corresponding MIC/LINE input. Front panel settings have no effect on split outputs.

NOTE: A PS40 can only power two Shure devices.

Using the P4M Personal Monitor Mixer

Once the basic set up is complete, use the P4M Personal Monitor Mixer to create a custom mix:

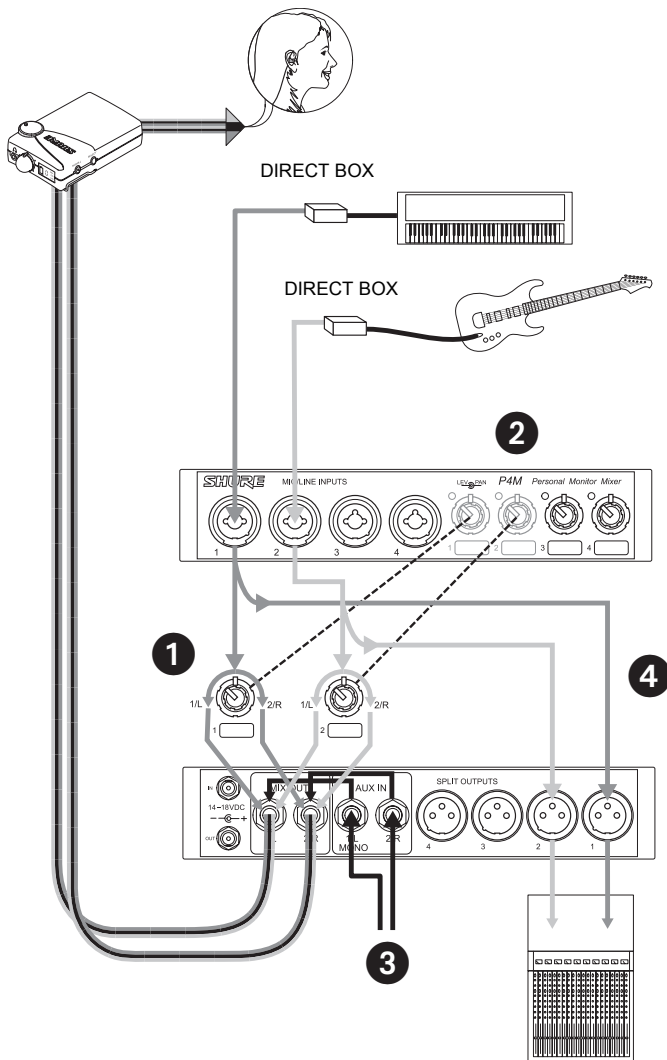

- 1 Mix the signal from each audio input using the corresponding CONCENTRIC LEVEL/PAN knobs:
OUTER RING: Use this to pan the signal to the left or right channel of the stereo mix.
INNER KNOB: Use this to control the level of the audio input.

- 2 Observe the Signal/Clip LEDs next to each CONCENTRIC LEVEL/PAN knob.

NOTE: Decrease the level of an input if the corresponding signal/clip LED is consistently red. If the level is decreased all the way and the LED remains red, the level of the input from the previous device in the audio chain is too high and should be decreased.

- 3 Up to two additional line-level audio sources (such as other mixers, a click track or a digital sequencer) may be added via the AUX IN inputs. These signals go directly to the MIX OUT outputs and are not affected by the CONCENTRIC LEVEL/PAN knobs.

- 4 To pass an unaltered signal through the P4M, use the corresponding SPLIT OUTPUT.

NOTE: Although the P4M does not provide phantom power for condenser microphones, the SPLIT OUTPUTS can pass phantom power from a phantom power supply to a microphone connected to the corresponding input jack.

CAUTION: Use a “direct box” when connecting guitars, keyboards, and other instruments to a mixing console through the P4M Mixer. The phantom power that mixing consoles provide for microphones can damage other instruments. Connect the instrument to the direct box then connect the direct box to the P4M Mixer input.

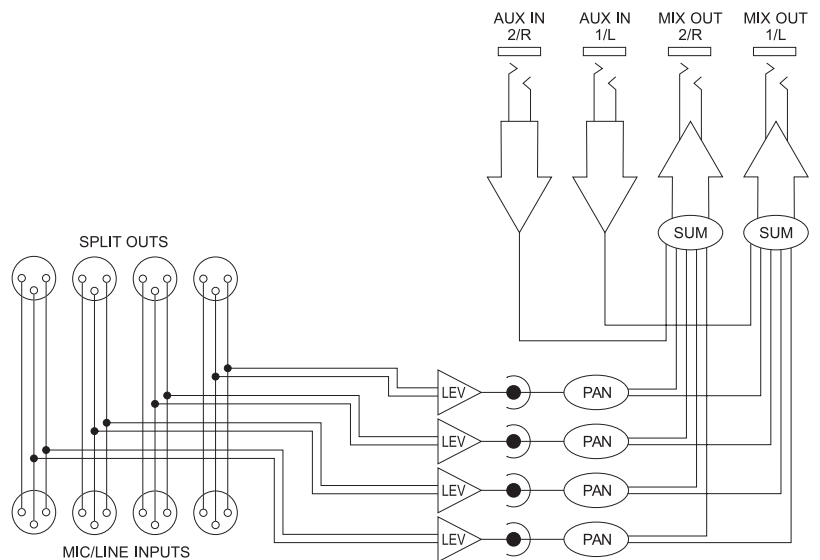

P4HW HARDWIRED PERSONAL MONITOR

Controls

- ❶ **Balance Knob:** Adjusts the left/right balance when the unit is in stereo and the Mix 1/Mix 2 balance when the unit is in Mix-Mode.
- ❷ **Scroll Button:** Controls the functions in the LCD screen. See *Using the Bodypack Features* on page 6.
- ❸ **Select Button:** Controls the functions in the LCD screen. See *Using the Bodypack Features* on page 6.
- ❹ **Battery Compartment:** Contains one 9 V alkaline battery.
- ❺ **Cable:** Attached female XLR “Y” cable for connection to audio sources.
- ❻ **ON/OFF/VOLUME Knob:** Turn clockwise past click to turn ON. Continue to turn clockwise to increase volume, counter-clockwise to decrease volume.
- ❼ **1/8" Stereo Earphone Output Jack:** Connects to earphones.
- ❽ **Belt Clip:** Attaches the bodypack to a belt, guitar strap or waist band.
- ❾ **LCD Screen:** Displays the current status of each function. See *Reading the LCD Screen* on page 6.

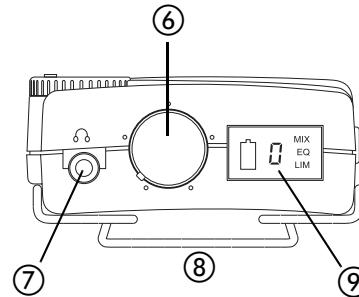
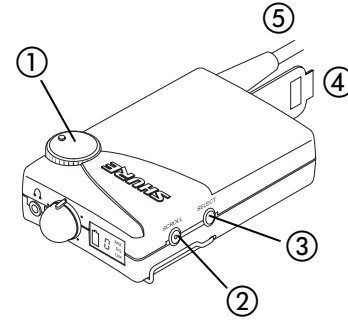

BATTERY INSTALLATION

1. Open the battery door by pushing down and sliding towards cable.
2. Insert a fresh 9 V alkaline battery with the +/- terminals properly positioned.
3. Close the battery door.

NOTE: If battery compartment door will not close, the battery is not properly inserted.

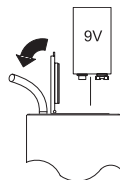

FIGURE 1

CONNECTING TO THE MIXER

1. Connect the “Y” cable of the bodypack to the mixer MIX OUT jacks using the supplied 1/4" to male XLR cables.
2. Turn the ON/OFF/VOLUME knob clockwise past click (ON).
3. Plug earphones into earphone output jack.
4. Insert earphones into ears as instructed in the earphone user's guide.
5. Increase the volume slowly to a comfortable listening level.
6. Clip the bodypack onto a belt or guitar strap.

READING THE LCD SCREEN

The LCD screen displays the status of each function, as follows:

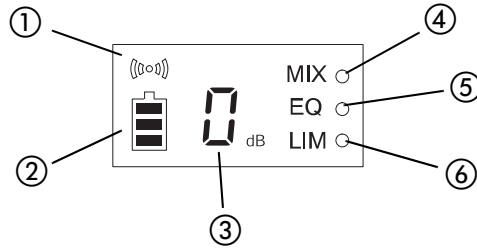

1 Input Level Meter: 3-segment input level meter displays level of incoming signal. Always check for clipping prior to inserting earphones into ears.

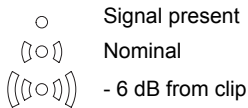

2 Battery Life Meter: Indicates the amount of voltage left in the battery. If no indicators are present, change the battery as soon as possible.

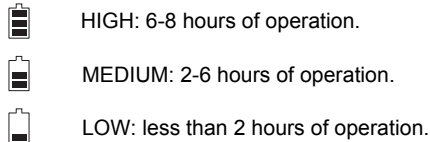

NOTE: Battery life depends on many variables, including battery type (brand), earphones used, and volume setting.

3 Input Attenuation: Displays the sensitivity of the bodypack's input. Use "0 dB" attenuation for low levels (-10 dBu), and use "-15 dB" attenuation for higher levels (+4 dBV).

4 MixMode (MIX): Allows the user to receive the monitor mix in either MixMode (MIX ON) or Stereo (MIX OFF). If the bodypack is receiving only one signal, use MIX ON. See *Mono, Stereo and MixMode Control* on 7.

5 High Frequency Equalization (EQ): Adds 6 dB at 10 kHz for improved treble response.

6 Limiter (LIM): Activates and deactivates an internal limiter which provides protection against loud signals.



Warning:
Turning the Limiter OFF defeats protection against hazardous sound levels.

USING THE BODYPACK FEATURES

1. Push either the SCROLL or SELECT button to activate the LCD screen.
2. Push and hold the SCROLL button until the desired function (0/-15, MIX, EQ, or LIM) is underscored.
3. Push the SELECT button to toggle the function ON or OFF. A function is ON when a dot appears to the right of the function symbol.
4. Push the SCROLL button to activate the change.

LOCKING THE DISPLAY

1. Adjust all functions to desired settings.
2. Hold down the SCROLL and SELECT buttons simultaneously for five seconds (see Figure 2 [A]). The display will show two dashed lines to signify that lock out is engaged (see Figure 2 [B]).

NOTE: When lock-out is engaged, the SCROLL and SELECT buttons will still light the LCD screen, but will not change the status of any of the functions.

3. To unlock the display, hold the SCROLL and SELECT buttons simultaneously for five seconds until the LCD returns to a numeric display.

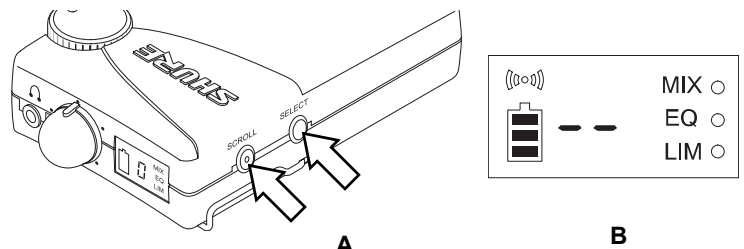

FIGURE 2

MONO, STEREO AND MIXMODE CONTROL

The Hardwired Personal Performance Pack provides simple configuration of a monitor mix and enables the user to customize an individual mix in a multiple mix environment. Three sound processing modes are available: mono, stereo, and MixMode.

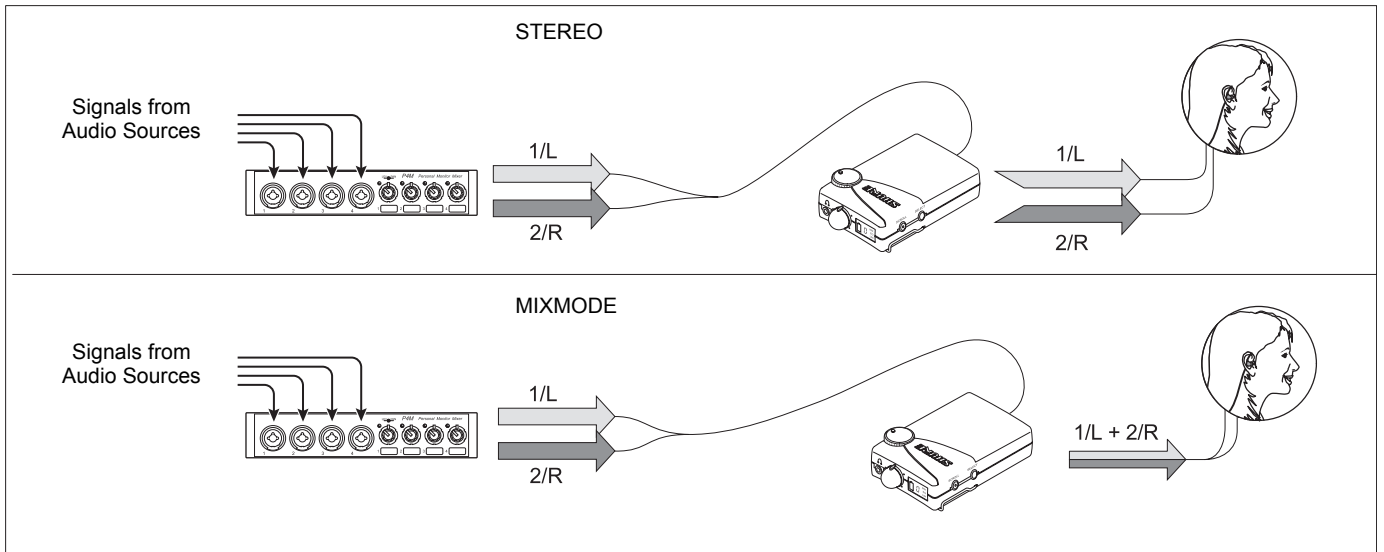

FIGURE 3

Mono: The bodypack receives one signal from the mixer and sends that signal to both earphones. Adjust the balance knob all the way toward the side that contains the mono signal. For mono signals, use MixMode (MIX ON).

Stereo: The bodypack receives two signals (L and R) from the mixer and sends the signals to the left and right earphones, respectively. The balance knob adjusts the balance between the left and right earphones. For stereo signals, use the MIX OFF setting.

MixMode: Allows the performer to easily adjust the monitor mix *during* the performance. In MixMode, the bodypack receives two signals, such as a band mix and a vocal mix. The balance knob adjusts the mix of these two signals. The mixed signal is sent to both the left and right earphones. For example, if the band is overpowering the vocals in the mix, the vocal levels can be increased and the band mix level decreased by simply adjusting the balance knob (see Figure 4). For MixMode operation, use MIX ON.

USING MIXMODE

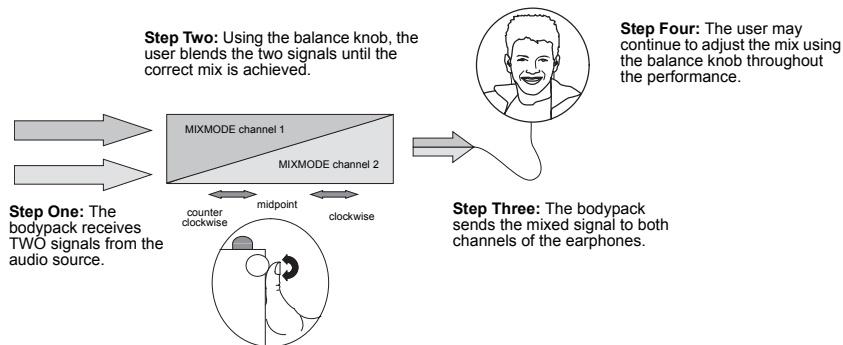

FIGURE 4

P4M PERSONAL MONITOR MIXER SPECIFICATIONS

Measurement Conditions (unless otherwise specified): full gain; 1 kHz, one channel activated; source impedances: Mic 150 Ω, Aux Level 150 Ω; terminations: Line 600 Ω.

Frequency Response (Ref 1 KHz, controls centered)

20 Hz to 20 KHz ± 2 dB

LEDs: Resultant Mix Out Level

Green: -30 dBV

Yellow: -10 dBV

Red: 0 dBV

Current

120 mA max

Power Requirements

Operating voltage 14–18 Vdc

Supplied with one of the following external power supplies:

- Model PS40: 120 Vac, 60 Hz input.
- Model PS40E, Model PS40UK: 230 Vac, 50/60 Hz input.

NOTE: Courtesy DC connector is protected from short by a self-resetting "Polyfuse". Maximum recommended load is 250mA. (2 P4Ms or 1 P4T.)

Phantom Power

The P4M does not produce phantom power, but phantom power is allowed to pass through split outputs 1–4 to inputs 1–4 respectively.

Polarity

All outputs in polarity with all inputs.

XLR pin 2 is "hot" with respect to pin 3; pin 1 is ground.

1/4" TRS tip is "hot" with respect to ring; sleeve is ground.

Temperature Range

Operating: -7° to 49° C (20° to 120° F)

Storage: -29° to 74° C (-20° to 165° F)

Overall Dimensions

44 mm H x 218 mm W x 162 mm D
(1.72 x 8.60 x 6.37 inches)

Net Weight

1.20 Kg (2 lbs, 10 oz)

INPUT Specifications

	Input	
	1–4 (front panel)	Aux In
Gain (Maximum)	43 dB	0 dB
Impedance (at 1KHz)	5800 Ω	18 kΩ (each) 9100 Ω (1/L mono)
Input Clipping Level	+12dBV	+12 dBV
Crosstalk	-100 dB	-90 dB
Common Mode Rejection	> 75 dB	> 70 dB

OUTPUT Specifications

	Output	
	Split 1–4	Mix Out
Impedance	N/A	500 Ω
Output Clipping Level	N/A	+5 dBV (10 kΩ balanced load, -30 dBV input ch. 1–4.)
Noise (100 Hz to 22 kHz)	-110 dBV	-100 dBV (all controls CCW) -62 dBV (all controls CW)
Distortion (THD) at 1kHz)	.0005%	< .05% (0 dBV output)
Crosstalk	-100 dB	-70 dB

Furnished Accessories

Single Mount Rack Bracket	53A8484
Dual Mount Rack Bracket	53B8484
Straddle Bars	53A8443
AC Adaptor	PS40 (120V), PS40E (230V), PS40UK (230V)
DC Jumper Cable, 24"	95A8420
XLR to 1/4" Adapter Cable, 9"	90B8861

P4HW HARDWIRED PERSONAL MONITOR SPECIFICATIONS

Frequency Response

20 to 20,000 Hz

Total Harmonic Distortion

< .1% (measured at -10 dBu out)

Channel Separation

35 dB (minimum)

Signal-to-noise ratio

85 dB (minimum)

Maximum Output Level

+5 dBu at 1% THD

Maximum Input Level

+7 dBu, input pad OFF

+22 dBu, input pad ON

Actual Impedance

> 40 kΩ

Audio Output Connector

3.5 mm stereo (left=tip, right=ring, ground=sleeve)

Power Requirements

9 V Alkaline battery

Battery Life

Up to 8 hours, volume dependant

Phantom Power Protection

Up to 60 VDC

CERTIFICATIONS

P4HW: Authorized under the DECLARATION OF CONFORMITY provision FCC part 15 as a Class B digital device. Tested to comply with FCC standards. FOR HOME OR OFFICE USE. This product complies with part 15 of the FCC rules. Operation is subject to the following two conditions: (1) this device may not cause harmful interference, and (2) this device must accept any interference received, including interference that may cause undesired operation. Changes or modifications not expressly approved by Shure Incorporated could void your authority to operate this equipment.

This equipment has been tested and found to comply with the limits for a class B digital device, pursuant to Part 15 of the FCC rules. These limits are designed to provide reasonable protection against harmful interference in a residential installation.

This equipment generates, uses and can radiate radio frequency energy and, if not installed and used in accordance with the instructions, may cause harmful interference to radio communications. However, there is no guarantee that interference will not occur in a particular installation. If this equipment does cause harmful interference to radio or television reception, which can be determined by turning the equipment off and on, the user is encouraged to try to correct the interference by one or more of the following measures:

- Reorient or relocate the receiving antenna
- Increase the separation between the equipment and the receiver
- Connect the equipment into an outlet on a circuit different from that to which the receiver is connected
- Consult the dealer or an experienced radio/TV technician for help

This class B digital apparatus complies with Canadian ICES-003.

Eligible to bear CE marking: 

Conforms to European EMC directive 89/336/EEC: Professional Audio Products Standard EN 55103 (1996); Part 1 (emissions) and Part 2 (immunity). The P4HW is intended for use in environments E1 (residential) and E2 (light industrial) as defined in European EMC standard EN 55103. It meets the applicable tests and performance criteria found in the standard for these environments. EMC conformance is based on the use of shielded interconnecting cables.

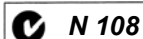

P4M: Eligible to bear CE marking. Conforms to European Union directive 89/336/EEC. Meets applicable tests and performance criteria in European Standard EN 55103 (1996) Parts 1 and 2, for residential (E1) and light industrial (E2) environments.

PS40: Conforms to applicable U.S. and Canadian electrical and safety standards.

PS40E/PS40UK: Conforms to European low voltage directive 72/23/EEC. Eligible to bear CE marking.

RACK MOUNTING

The mixer features a sturdy 1/2-rack chassis. Brackets and straddle bars ensure a secure installation, eliminating the sagging and bending found in most 1/2-rack designs.

CAUTION: Do not torque the screws too tightly, or the chassis may be damaged.

Single Unit

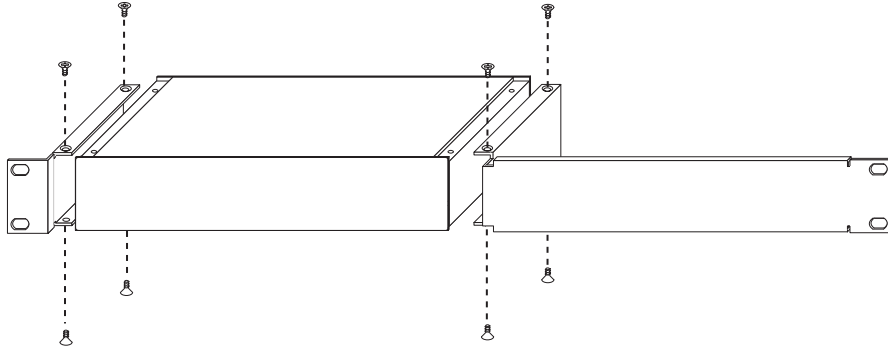

Dual-Mounted Units

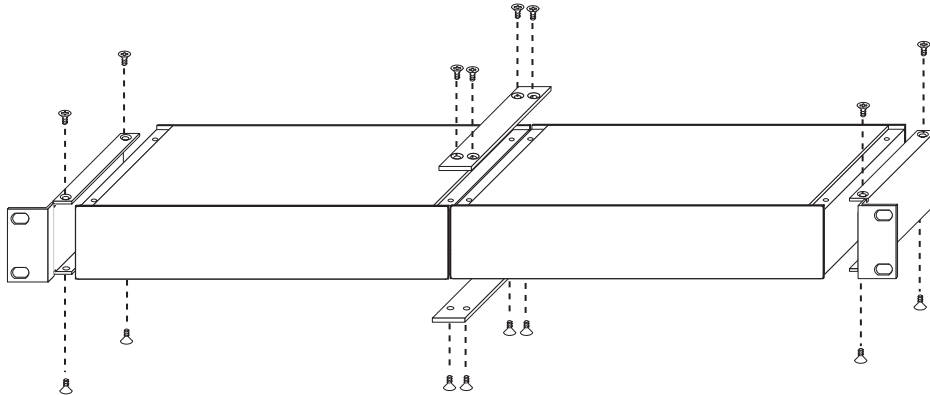

NOTE: Be sure to use both straddle bars when installing dual units.

Mounting in an Equipment Rack

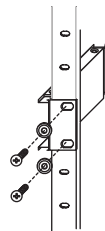
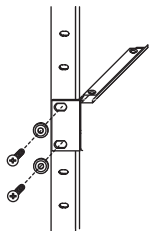

FCC DECLARATION OF CONFORMITY

We,
of

Shure Incorporated
5800 Touhy Ave
Niles, Illinois, 60714-4608 U.S.A
(847) 600-2000

Declare under our sole responsibility that the following product

Model: P4HW Description: Hard Wired Personal Monitor

Has been tested and found to comply with the limits for a Class B digital device, and approved under the Declaration of Conformity provision of the Part 15 of the FCC rules.

Operation is subjected to the following two conditions:

1. This device may not cause harmful interference.
2. This device must accept any interference received, including interference that may cause undesired operation.

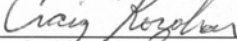
Signed  Date October 14, 2003
Name, Title Craig Kozokar
EMC Project Engineer, Corporate Quality, Shure Incorporated

EU DECLARATION OF CONFORMITY

We,
of

Shure Incorporated
5800 Touhy Ave
Niles, Illinois, 60714-4608 U.S.A
(847) 600-2000

Declare under our sole responsibility that the following product

Model: P4R, P4T, P4M Description: Personal Stereo Monitor System
PS40E, PS40UK

to which this Declaration relates

- are in conformity to European Low Voltage Directive 73/23/EEC
- are in conformity to European EMC Directive 89/336/EEC
- are in conformity to European R&TTE Directive 1999/5/EC
- are in conformity to European CE Marking Directive 93/68/EEC

The product complies with the following product family, harmonized or national standards:

P4R, P4T: EN 301 489 Part 1 and 9, ETSI 300 422-1 and ETSI 300 422-2
P4M: EN55103-1, EN55103-2
PS40E, PS40UK: EN60950, EN61000-3-2, EN 61000-3-3

Manufacturer: Shure Incorporated

Signed  Date October 27, 2003
Name, Title Craig Kozokar
EMC Project Engineer, Corporate Quality, Shure Incorporated

European Contact: Shure Europe GmbH
Wannenacker Str. 28, 74078 Heilbronn, Germany
Phone: 49-7131-7214-0, Fax: 49-7131-7214-14

SHURE®

SHURE Incorporated <http://www.shure.com>
United States, Canada, Latin America, Caribbean:
5800 W. Touhy Avenue, Niles, IL 60714-4608, U.S.A.
Phone: 847-600-2000 U.S. Fax: 847-600-1212 Intl Fax: 847-600-6446
Europe, Middle East, Africa:
Shure Europe GmbH, Phone: 49-7131-72140 Fax: 49-7131-721414
Asia, Pacific:
Shure Asia Limited, Phone: 852-2893-4290 Fax: 852-2893-4055